

COMAV's Gravimetric Diverter Valve are designed to diverter granule, powder and pellet from one to two ways.

Thanks to a two different special execution is also used for abrasive product and in diary making of DTG2 an universal valve for all kind of application with many accessories that match the customer's needs.



APPLICATIONS

- GRAVIMETRIC DISCHARGE
- POWDER
- GRANULE
- PELLETS
- DIVERTERS

DESIGN

- SIZE: DN150, DN200, DN 250
- BODY: CARBON STEEL, ALUMINIUM, STAINLESS STEEL AISI304/316L
- FLAP: PAINTED CARBON STEEL, STAINLESS STEEL AISI 304/316L
- SEAL: TEFLON
- OPERATION: CYLINDER OR MANUAL

FEATURES

- PRESSURE: ATM
- TEMPERATURE: MAX 100 °C
- FLY SWITCH
- RUGGED DESIGN
- LONG LIFE

OPTIONALS

- SPECIAL EXECUTION FOR ABRASIVE PRODUCT
- INNER POLISHED TREATMENT
- FOOD GRADE APPROVED MATERIAL
- VARIOUS CHEMICAL TREATMENT ON BODY/FLAP
- HIGH TEMPERATURE VERSION
- INSPECTION DOOR WITH SAFETY KEY
- INNER CONE FOR FLOWRATE REDUCTION
- SIZE ON REQUEST
- KIT CONNECTING PIPE

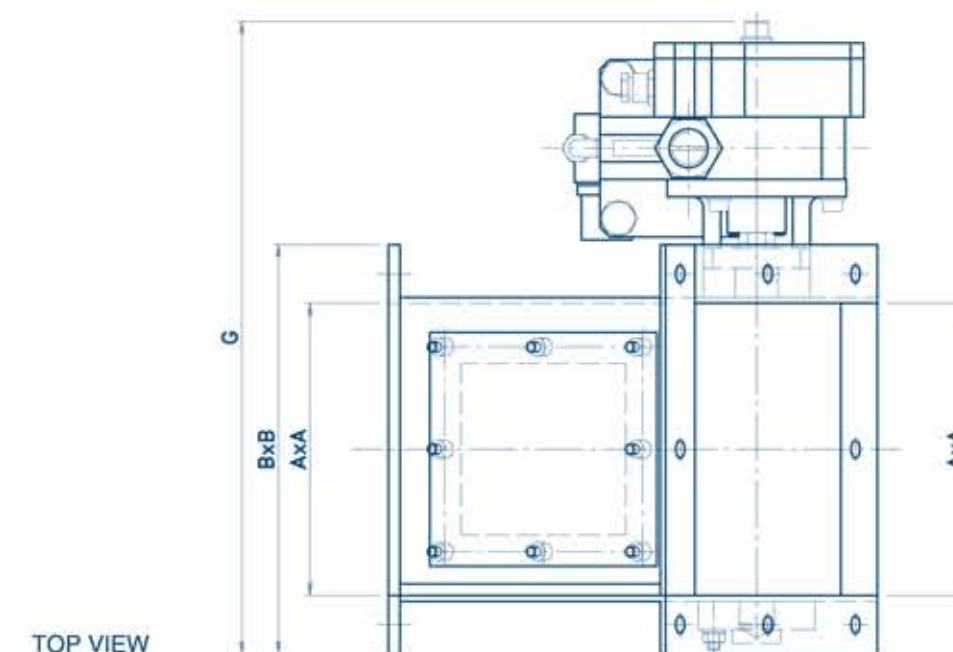
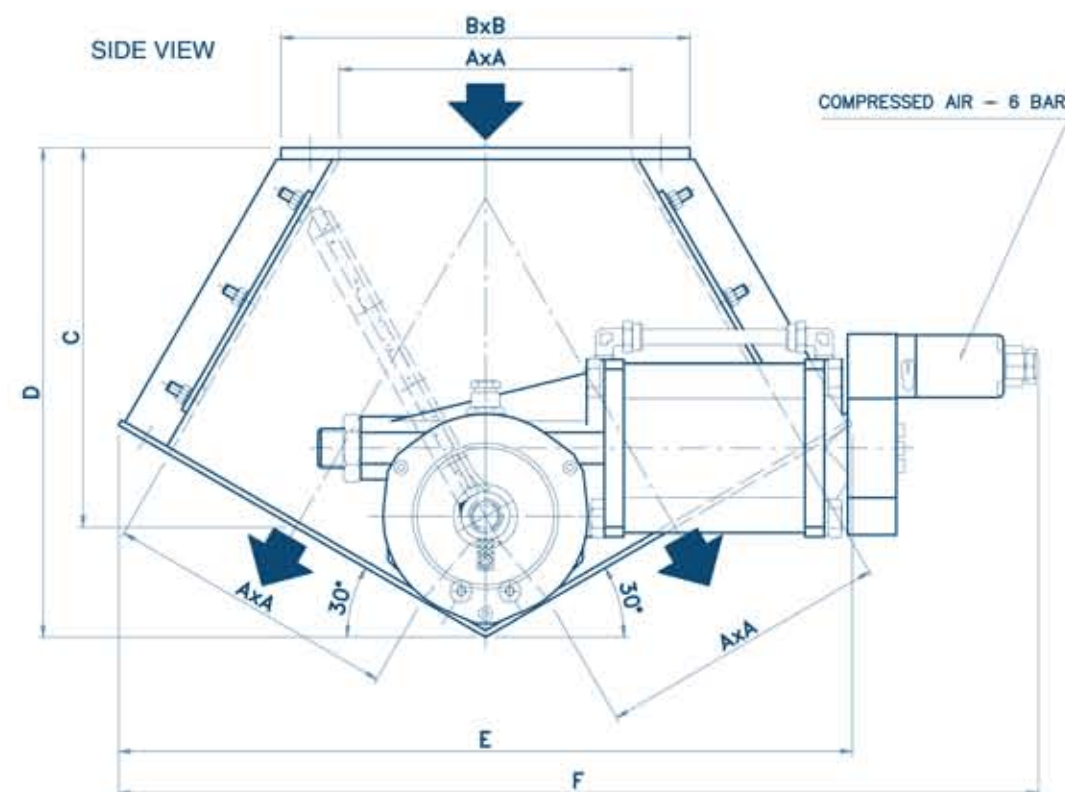

	A	B	C	D	E	F	G	WEIGHT
150	150	210	195	250	375	470	325	Kg -
200	200	266	275	340	480	645	380	Kg -
250	250	316	325	400	565	700	430	Kg -

BROCHURE



COMPLIANCE



II 2/3DC T135*