



COMAV'S SLIDE GATE VALVE SGB is designed for your different aims as shut off the flow of product and to dose the product during the discharge

SGB thanks to a two opposite cylinders sets the dosing trough the double blades having always a free opening, moreover its compact design allows a wide application from outlets of dry bulk storage bins, silos, conveyors and other discharge points.

SGB twin blades is used where dust sealing is request, thank to self-calibrated spring that extend the service life by compensating for wear.

The slide gate valve meets the most demanding application on the market.

### APPLICATIONS

- GRAVIMETRIC FLOW
- POWDER
- GRANULE
- PELLETS

### DESIGN

- SIZE: DN 200
- BODY: ALUMINIUM
- BLADE: STAINLESS STEEL AISI 304/316L
- MAIN SEAL: NOVATRON
- OPERATION: DOUBLE CYLINDER

### FEATURES

- PRESSURE: ATM, 1 BAR
- TEMPERATURE: MAX 100 °C
- RUGGED DESIGN
- LONG LIFE

### OPTIONALS

- SPECIAL EXECUTION FOR ABRASIVE PRODUCT
- FOOD GRADE APPROVED MATERIAL
- VARIOUS CHEMICAL TREATMENT ON BODY/FLAP
- VARIOUS SEAL MATERIAL
- HIGH TEMPERATURE VERSION
- CUSTOM SIZE

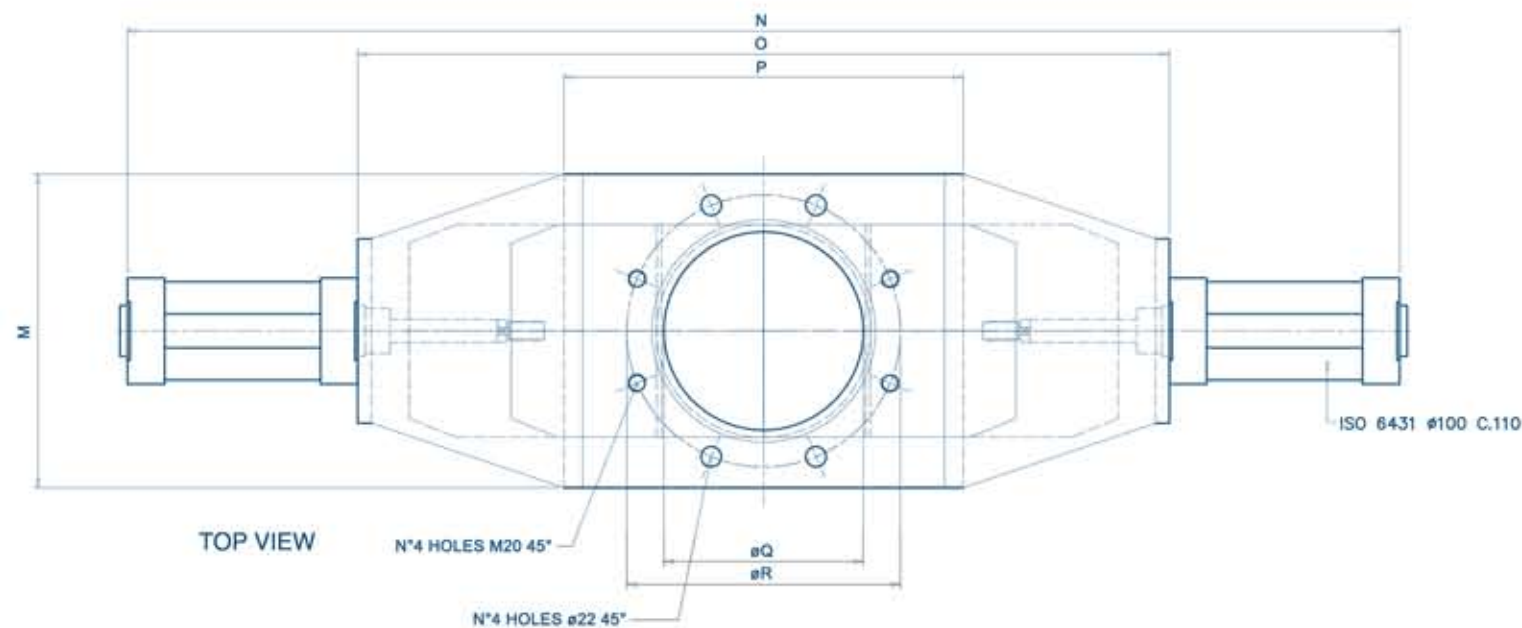
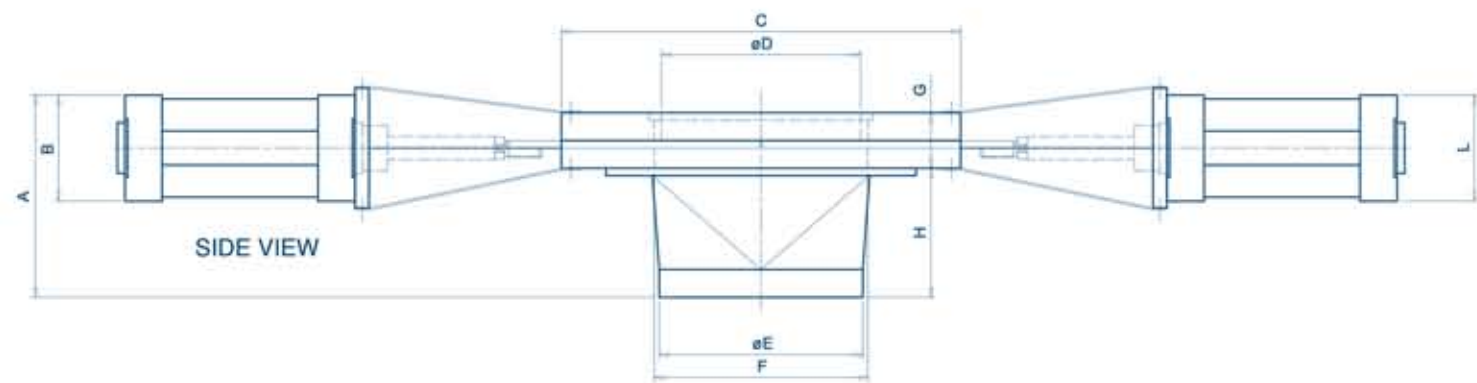

	A	B	C	ØD	ØE	F	G	H	L	M	N	O	P	ØQ	ØR
200	220	115	430	215	219,1	230X230	60	140	115	340	1370	875	430	215	295

BROCHURE



COMPLIANCE



II 2/3DC T135\*