

COMAV's RIGID PIPE DIVERter VALVE are designed to diverter granule, powder and pellet from one way to two ways.

The unique design of VDF prevents a damage of product also in condition of medium pressure thanks to pressurized seal at inlet and outlet spouts, moreover reduce the maintenance with Quick Repair in Line.



### APPLICATIONS

- DILUTE PHASE AND VACUUM
- POWDER
- GRANULE
- PELLETS
- DIVERTERS

### DESIGN

- SIZE: FROM DN80, TO DN100
- BODY: PAINTED CARBON STEEL  
STAINLESS STEEL AISI 304 OR AISI 316L
- INNER PIPE: STAINLESS STEEL AISI 304/316L  
SPECIAL MATERIAL FOR HARD APPLICATION
- INLET SEAL GROUP: SEMISPHERE MADE OF NOVATRON + PRESSURIZED SEAL
- DRIVE: CYLINDER

### FEATURES

- PRESSURE: 1 BAR
- TEMPERATURE: MAX 100 °C
- LONG LIFE FOR SEAL SELF-CLEANING
- QUICK REPAIR IN LINE
- FLY SWITCH

### OPTIONALS

- FOOD GRADE VERSION
- SPECIAL EXECUTION FOR ABRASIVE PRODUCT
- SPECIAL PIPE ON REQUEST FOR SPECIAL APPLICATION
- SPECIAL EXECUTION FOR DIRECT FITTING AT PIPING
- HIGH TEMPERATURE VERSION
- ADAPTOR KIT
- HAND WHEEL
- PROXIMITY SWITCH
- SIZE ON REQUEST
- 3 WAYS VERSION

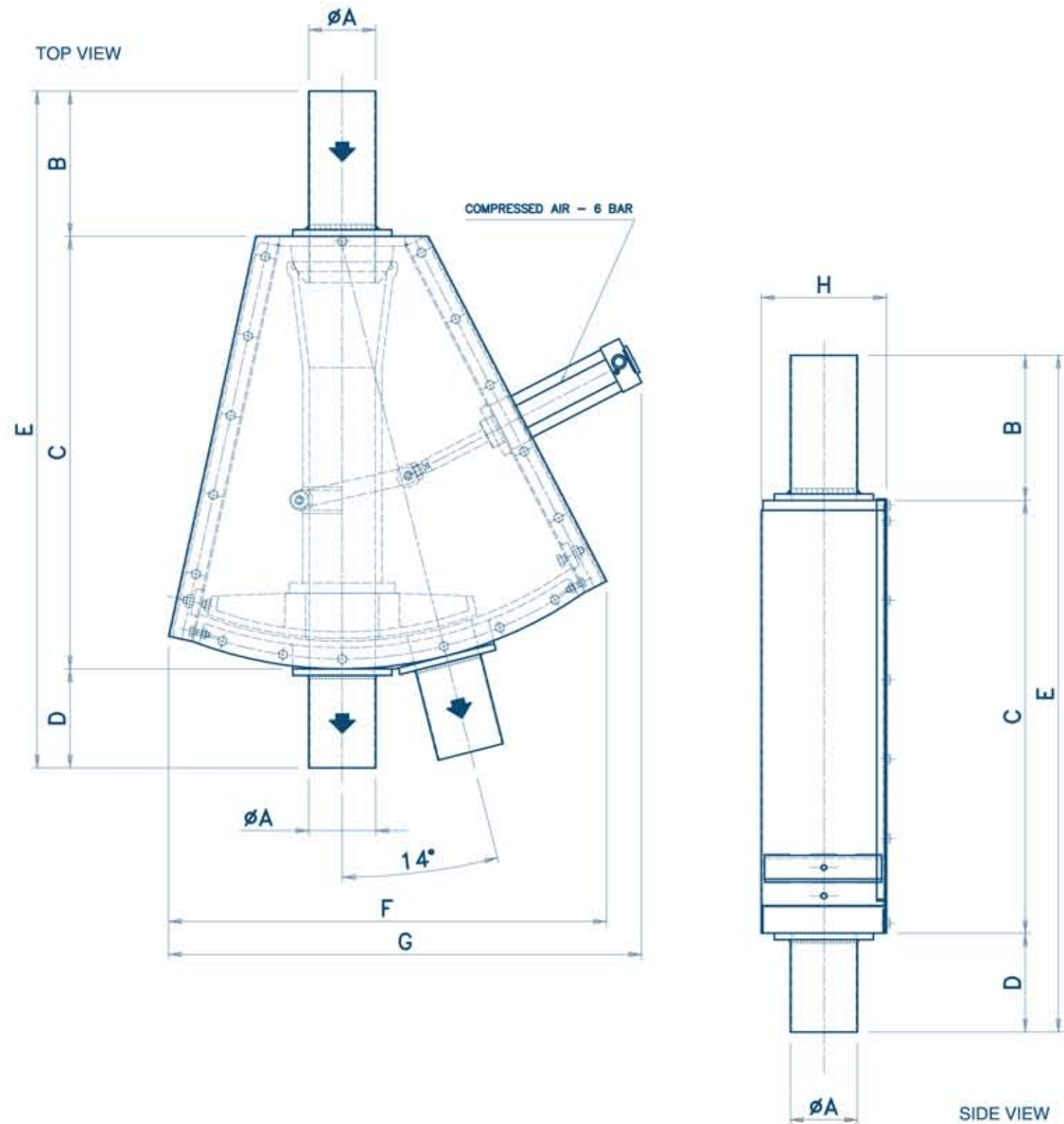

	A	B	C	D	E	F	G	H
80	88,9	150	430	150	955	665	715	190
100	101,6	220	655	150	1025	665	715	190



BROCHURE

COMPLIANCE



II 2/3DC T135\*