

# VSDT DROP THROUGH ROTARY VALVE

COMAV'S DROP THROUGH ROTARY VALVES are designed to handle pneumatic conveying in dilute phase for every industrial application such as food, plastic, rubber, chemical, pharmaceutical and mining. Thanks to COMAV'S TECHNOLOGY our valve is used for powder, granule, flakes, pellets assuring a perfect reliability and meeting a wide range of customer's requirements. The round flange allows an easy connection with line/equipment.



## APPLICATIONS

- METERING
- DISCHARGE
- POWDER
- GRANULE
- GENERAL PNEUMATIC CONVEYING

## DESIGN

- FLANGING: ROUND UNI PN 10
- SIZE: DN200, DN250
- HOUSING: CAST IRON CASTING
- ROTOR: WELDED CARBON STEEL OR STAINLESS STEEL AISI 304, AISI 316L
- DRIVE: DIRECT DRIVE OR CHAIN TRANSMISSION AVAILABLE IN BARE SHAFT VERSION. ALL OUR DRIVES CAN BE CONTROLLED BY INVERTER.
- ROBUST & COMPACT DESIGN WITH MINIMAL ROTOR TOLERANCE

## FEATURES

- PRESSURE: 1,5 BAR
- TEMPERATURE: MAX 65 °C
- AIR LEAKAGE: SEE CHART
- INTEGRATED CASTING INNER HOPPER ( BETTER FILLING EFFICIENCY)
- 8 VANES OPEN OR CLOSED ENDS ROTOR

## OPTIONALS

- DIFFERENT ROTORS FOR DIFFERENT PRODUCTS
- NICKEL COATING
- NICKEL COATING FOOD GRADE
- HARD CHROMIUM PLATING
- VARIOUS POLISHING DEGREES
- FOOD GRADE GASKET
- HIGH TEMPERATURE CONFIGURATION
- FEEDING SHOE
- FEEDING HOPPER COMPLETE WITH AIR INTAKES
- AIR BLOW-IN PURGE
- AIR INTAKES HOLES ON HOUSING
- SPEED DISPLAY
- SPEED CONTROLLER

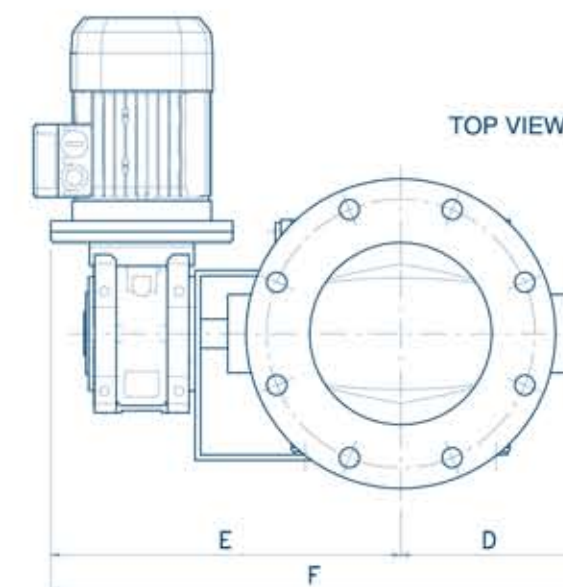
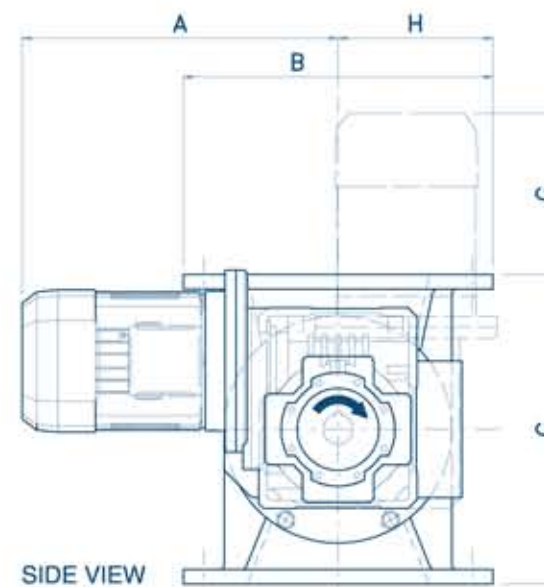

	A	B	C	D	E	F	G	H	L./Rev.	Rev./1' max	POWER	WEIGHT
200	350	ø340	340	195	565	565	177	75	4,5	30	Kw 0.55	Kg 95
250	350	ø395	400	210	613	613	147	75	8	30	Kw 0.75	Kg 115

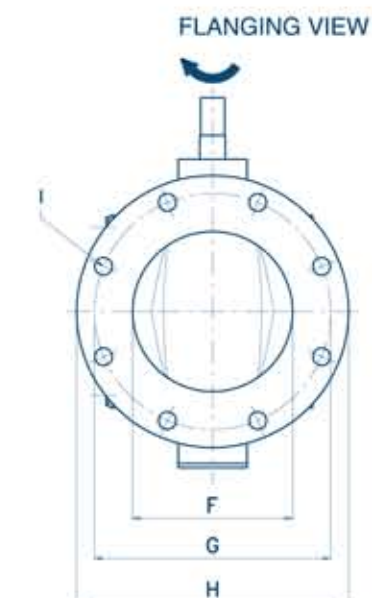
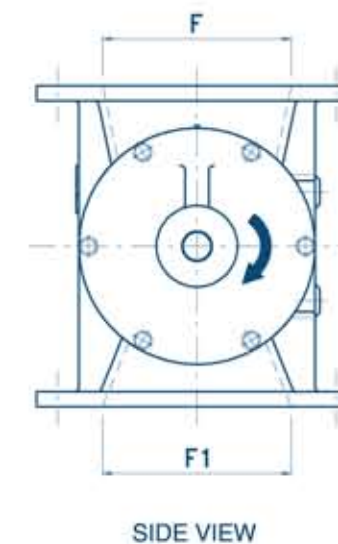
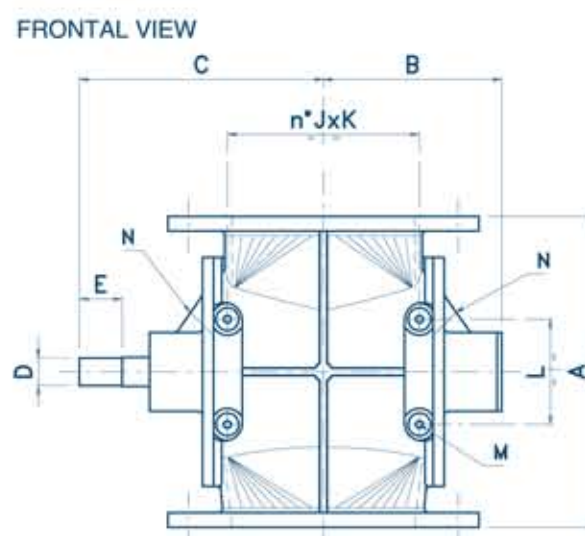

	A	B	C	D	E	F	F1	G	H	I	J	K	L	M	L./Rev.	N
200	340	195	267	ø30	47	ø200	ø200	ø295	ø340	8Xø22	1	210	115	4xM10	4,5	1/8" GAS
250	400	205	282	ø30	47	ø265	ø250	ø350	ø395	12Xø22	2	117,5	125	6xM10	8	1/8" GAS



COMPLIANCE



II 1/3DC T135° - II 2/3DC T135°