



**MIX S.r.l.**

MIXING SYSTEMS AND  
COMPONENTS FOR PLANTS

[www.mixitaly.com](http://www.mixitaly.com)

# Bag Filters



 ATEX RANGE AVAILABLE

# Combination table DN 350÷1550



## Identification

**N:** Standard  
**A:** Atex

## Filtering elements

**C:** Cartridge DN120 (fig.04)  
**L:** Bag DN120 (fig.05)

## Housing diameter

**2:** DN 350  
**3:** DN 540  
**4:** DN 790  
**5:** DN 950  
**6:** DN 1100  
**7:** DN 1300  
**8:** DN 1550

## Nominal filtering surface

See specific data sheet  
Example  
**A24:** 2.4 mq  
**B24:** 24 mq  
**C12:** 120 mq  
.....:..... mq

## Filtering elements extraction

TIPO	E	F	J	L*
DN	fig.01	fig.02	fig.01	fig.03
350		✓		
540	✓	✓		✓
790	✓			✓
950	✓			✓
1100	✓		✓**	✓
1300		✓	✓	✓
1550		✓	✓	✓

\* Universal solution that allows releasing the filtering elements from above and from the door  
\*\* Special solution with double door

## Air Outlet Type

**D:** flanged lateral cylindrical unload set-up for conveying pipe (fig.06 DN 350-1100 / fig.07 DN 1300-1550)  
**H:** Unload with Electric fan (fig.08 DN 350-1100 / fig.09 DN 1300-1550)  
**M:** Unload with Electric fan with Electrical panel

## Operating Condition

**S:** Atmospheric (fig.10)  
**V:** Vacuum\* (fig.11)  
**P:** Atmospheric Resistant to explosion pressure impact  $P_{red}$  0.48 bar (fig.11)  
**Q:** Vacuum\* Resistant to explosion pressure impact  $P_{red}$  0.48 bar (fig.11)  
**R:** Atmospheric Resistant to explosion pressure impact. Set-up for diaphragm.  $P_{red}$  0.48 bar (fig.12)  
**X:** Vacuum\* Resistant to explosion pressure impact. Set-up for diaphragm.  $P_{red}$  0.48 bar (fig.12)  
**NOTE:** The filters with  $P_{red} = 1$  bar are special to be managed on request  
\* - 0,6 bar underpressure = 400 mbar absolute

## DN 350 - 1100

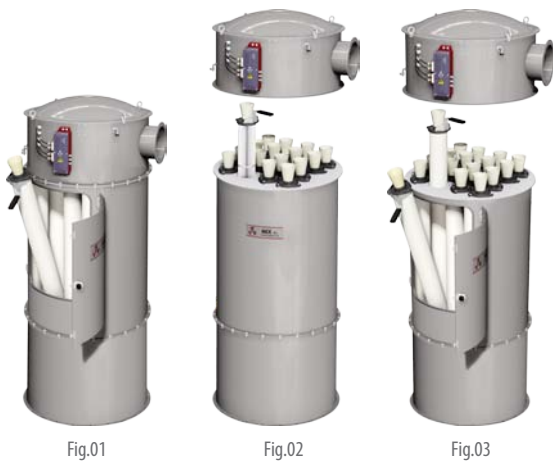

## DN 1300 - 1550



Fig.06



Fig.07



Fig.08

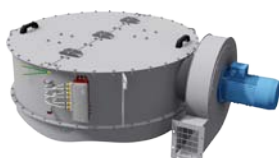

Fig.09



Fig.10



Fig.11

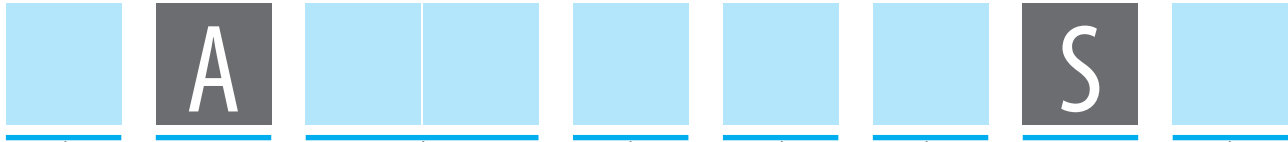

Fig.12



Fig.04

Fig.05



### Structural frame manufacturing material

- 1: Carbon Steel Mix standard paint
- 2: Parts in contact with product in AISI 304
- 3: Carbon Steel food EPOX paint NOT CERTIFIED \*
- 4: Parts in contact and external parts in AISI 304
- 5: Central and upper housing in AISI 304, Carbon Steel or Aluminium cover, galvanised Carbon Steel dish
- 9: Parts in contact with the product Certified for Food Use. - Regulation (EC) n.1935/2004 (only for models with bags)

\* Special solution

DN	Atmospheric Filters	EX-PROOF / VACUUM Filters
350	2/5/9	2/5/9
540	2/4/5/9	1/2/4/9
790	2/4/5/9	1/2/4/9
950	1/2/4/9	1/2/4/9
1100	1/2/4/9	1/2/4/9
1300	1/2/3/4/9	1/2/3/4/9
1550	1/2/3/4/9	1/2/3/4/9

Type	Fan motor power
A	0,75 kW
C	1,1 kW
E	1,5 kW
G	2,2 kW
L	3 kW
M	4 kW
P	5,5 kW
R	7,5 kW
T	11 kW
Z	without fan

### Sequencer Voltage

- 4: 24 VAC-VDC
- 5: 115-230 VAC
- 6: (24V AC/DC - 115/230V AC)
- 7: (24V AC/DC - 115/230V AC) with hour meter
- 8\*: (24V AC/DC - 115/230V AC) with pressure differential

\* DN1550 comes with 2 off sequential timers, and one of them is equipped with a pressure differential.



### Fan motor voltage

- Z: Without electric fan
- 1: 400V, 50Hz three-phased
- 2: 460V, 60Hz three-phased
- 3: 380V, 60Hz three-phased

### Filtering fabric features

#### BAG FABRICS - Polyester needle felt

Stainless steel Filter Cage on request

Type	g/m <sup>2</sup>	Antistatic	Diaphragm	Notes
13	450	/	/	/
14	450	✓	/	Stainless steel fibres
16	550	/	/	/
17	470	/	✓	Polyurethane diaphragm 15
18	550	✓	/	Teflon-coated Stainless steel fibres
19	550	/	✓	PTFE diaphragm 3
20	450	/	/	Teflon-coated
21	550	/	/	Teflon-coated
22	550	✓	/	Stainless steel fibres
23	500	✓	✓	Stainless steel fibres - PTFE diaphragm 3
24	500	/	✓	PTFE diaphragm 5
25	500	✓	✓	Stainless steel fibres - PTFE diaphragm 5

#### CARTRIDGE FABRICS - Polyester

On request, inner support in stainless steel

Type	Ref. *	Antistatic	Surface	Notes
70	A	/	Standard	Premium Polyester
71	B	✓	Standard	Antistatic Premium - Polyester
72	E	/	Standard	Vibro Polyester
73	G	/	Increased	SKYFILTER®
74	J	✓	Standard	Water-Oil Repellent
75	M	/	Increased	Plus Polyester
76	P	/	Standard	Polyester

\* See specific data sheets

### Packing unit

- A: Vertical on pallet fully assembled
- C: Vertical on pallet with head disassembled (2 packages) DN 350-1100
- G: Horizontal on fully assembled cradles
- Z: Without packing unit

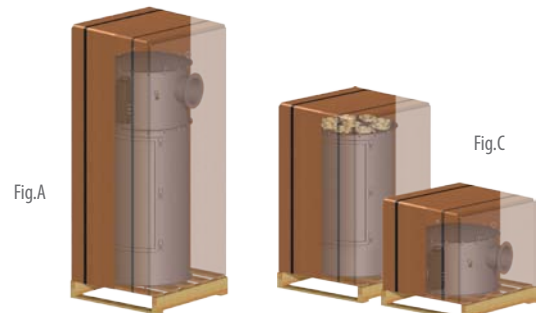

A-  
N- **SEL.....S**

A-  
N- **SFL.....S**

## UPPER BODY

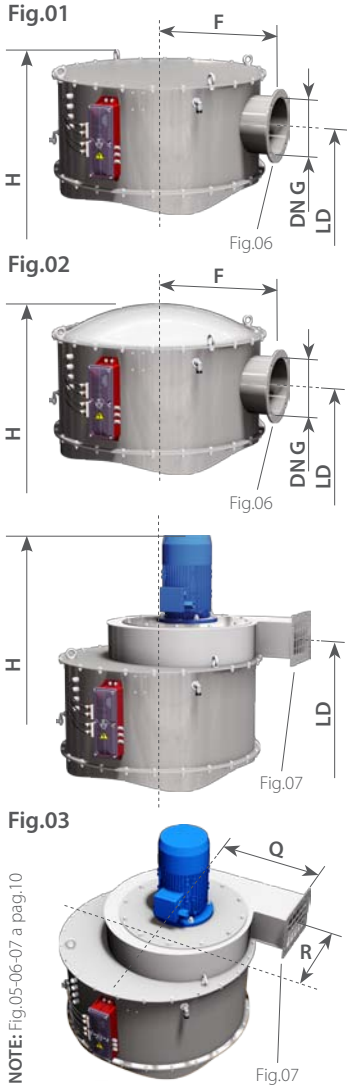

		CODE		Fig.	DN	H	LD	DN G	R	F	Q	kg	m2*	kW
ATEX	STD.	See combination table												
A-	N-	SFLD2A10S.A..ZZ.SA	1+6	350	1130	960	80	/	235	/	27	1	/	
A-	N-	SFLD2A17S.A..ZZ.SA	1+6	350	1630	1460	80	/	235	/	34	1,7	/	
A-	N-	S.LD3A21S.A..ZZ.SA	2+6	540	1165	980	150	/	370	/	65	2,1	/	
A-	N-	S.LD3A39S.A..ZZ.SA	2+6	540	1665	1480	150	/	370	/	81	3,9	/	
A-	N-	S.LD3A56S.A..ZZ.SA	2+6	540	2160	1975	150	/	370	/	91	5,6	/	
A-	N-	S.LD3A73S.A..ZZ.SC	2+6	540	2660	2475	150	/	370	/	105	7,3	/	
A-	N-	SELD4A48S.A..ZZ.SA	2+6	790	1225	940	200	/	495	/	110	4,8	/	
A-	N-	SELD4A86S.A..ZZ.SA	2+6	790	1725	1440	200	/	495	/	135	8,6	/	
A-	N-	SELD4B12S.A..ZZ.SA	2+6	790	2220	1935	200	/	495	/	154	12,4	/	
A-	N-	SELD4B16S.A..ZZ.SC	2+6	790	2760	2435	200	/	495	/	177	16,2	/	
A-	N-	SELD5A67S.A..ZZ.SA	1+6	950	1195	935	250	/	580	/	162	6,7	/	
A-	N-	SELD5B12S.A..ZZ.SA	1+6	950	1695	1435	250	/	580	/	195	12	/	
A-	N-	SELD5B17S.A..ZZ.SA	1+6	950	2190	1930	250	/	580	/	230	17,3	/	
A-	N-	SELD5B23S.A..ZZ.SC	1+6	950	2690	2430	250	/	580	/	262	22,7	/	
A-	N-	SELD5B25S.A..ZZ.SG	1+6	950	2930	2670	250	/	580	/	277	25,3	/	
A-	N-	SELD6A93S.A..ZZ.SA	1+6	1100	1195	935	250	/	660	/	205	9,3	/	
A-	N-	SELD6B17S.A..ZZ.SA	1+6	1100	1695	1435	250	/	660	/	246	16,7	/	
A-	N-	SELD6B24S.A..ZZ.SA	1+6	1100	2190	1930	250	/	660	/	290	24,1	/	
A-	N-	SELD6B32S.A..ZZ.SC	1+6	1100	2680	2430	250	/	660	/	331	31,6	/	
A-	N-	SELD6B35S.A..ZZ.SG	1+6	1100	2930	2670	250	/	660	/	350	35,2	/	
A-	N-	SFLH2A10S.A..A..SA	3+7	350	1460	1150	/	200	/	256	56	1	0,75	
A-	N-	SFLH2A17S.A..A..SA	3+7	350	1960	1640	/	200	/	256	63	1,7	0,75	
A-	N-	S.LH3A21S.A..A..SA	3+7	540	1485	1175	/	226	/	288	88	2,1	0,75	
A-	N-	S.LH3A39S.A..C..SA	3+7	540	1985	1675	/	226	/	288	106	3,9	1,1	
A-	N-	S.LH3A56S.A..E..SC	3+7	540	2510	2175	/	235	/	374	123	5,6	1,5	
A-	N-	S.LH3A73S.A..E..SC	3+7	540	3010	2675	/	235	/	374	136	7,3	1,5	
A-	N-	SELH4A48S.A..E..SA	3+7	790	1510	1180	/	300	/	400	140	4,8	1,5	
A-	N-	SELH4A86S.A..E..SA	3+7	790	2010	1680	/	300	/	400	166	8,6	1,5	
A-	N-	SELH4B12S.A..G..SC	3+7	790	2535	2175	/	300	/	400	188	12,4	2,2	
A-	N-	SELH4B16S.A..G..SC	3+7	790	3035	2675	/	300	/	400	212	16,2	2,2	
A-	N-	SELH5A67S.A..E..SA	3+7	950	1530	1200	/	345	/	484	197	6,7	1,5	
A-	N-	SELH5B12S.A..G..SA	3+7	950	2060	1700	/	345	/	484	234	12	2,2	
A-	N-	SELH5B17S.A..G..SC	3+7	950	2555	2195	/	345	/	484	269	17,3	2,2	
A-	N-	SELH5B23S.A..L..SC	3+7	950	3085	2700	/	290	/	515	318	22,7	3	
A-	N-	SELH5B25S.A..L..SG	3+7	950	3325	2940	/	290	/	515	334	25,3	3	
A-	N-	SELH6A93S.A..E..SA	3+7	1100	1530	1200	/	526	/	430	239	9,3	1,5	
A-	N-	SELH6B17S.A..G..SA	3+7	1100	2060	1700	/	526	/	430	284	16,7	2,2	
A-	N-	SELH6B24S.A..L..SC	3+7	1100	2585	2200	/	580	/	310	345	24,1	3	
A-	N-	SELH6B32S.A..L..SC	3+7	1100	3085	2700	/	580	/	310	386	31,6	3	
A-	N-	SELH6B35S.A..M..SG	3+7	1100	3390	2940	/	580	/	310	414	35,2	4	

## LOWER BODY



F - Without inspection door

E - With inspection door

\* Nominal surface

## A-N-SFL.....S

## A-N-SJL.....S

### UPPER BODY

Fig.01

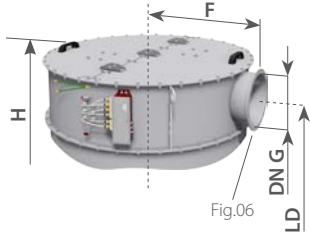
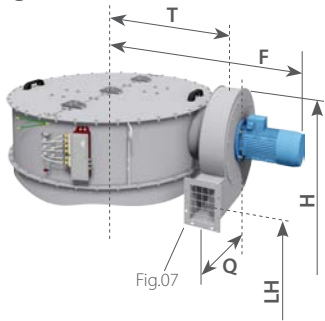

Fig.03



NOTE: Fig.05-06-07 a pag.10

### LOWER BODY

Fig.04

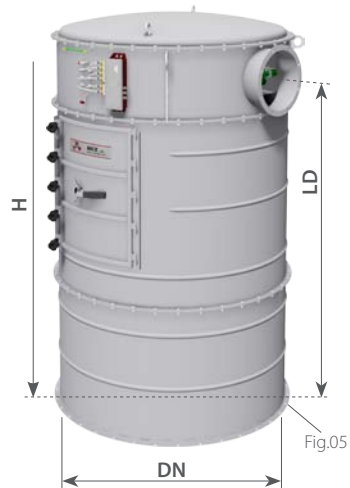

F - Without inspection door

J - Double inspection door

\* Nominal surface

		CODE		Fig.	DN	H	LD	LH	DN G	T	F	Q	kg	m2*	kW
ATEX	STD.	See combination table													
A-	N-	S.LD7B20S.A..ZZ.SA	1+6	1300	1670	1430	/	323	/	750	/	323	19,7	/	
A-	N-	S.LD7B29S.A..ZZ.SA	1+6	1300	2165	1925	/	323	/	750	/	383	28,5	/	
A-	N-	S.LD7B37S.A..ZZ.SG	1+6	1300	2665	2425	/	323	/	750	/	439	37,3	/	
A-	N-	S.LD7B42S.A..ZZ.SG	1+6	1300	2905	2665	/	323	/	750	/	465	41,5	/	
A-	N-	S.LD7B48S.A..ZZ.SG	1+6	1300	3275	3035	/	323	/	750	/	508	48	/	
A-	N-	S.LD8B26S.A..ZZ.SA	1+6	1550	1670	1430	/	323	/	875	/	438	25,8	/	
A-	N-	S.LD8B37S.A..ZZ.SA	1+6	1550	2165	1925	/	323	/	875	/	512	37,1	/	
A-	N-	S.LD8B49S.A..ZZ.SG	1+6	1550	2665	2425	/	323	/	875	/	580	48,6	/	
A-	N-	S.LD8B54S.A..ZZ.SG	1+6	1550	2905	2665	/	323	/	875	/	613	54,2	/	
A-	N-	S.LD8B63S.A..ZZ.SG	1+6	1550	3275	3035	/	323	/	875	/	667	62,7	/	
A-	N-	S.LH7B20S.A..L..SA	3+7	1300	1740	/	1180	/	823	1250	415	384	19,7	3	
A-	N-	S.LH7B29S.A..L..SA	3+7	1300	2235	/	1675	/	823	1250	415	444	28,5	3	
A-	N-	S.LH7B37S.A..M..SG	3+7	1300	2735	/	2175	/	823	1250	415	508	37,3	4	
A-	N-	S.LH7B42S.A..M..SG	3+7	1300	2975	/	2415	/	823	1250	415	534	41,5	4	
A-	N-	S.LH7B48S.A..P..SG	3+7	1300	3400	/	2705	/	882	1406	335	644	48	5,5	
A-	N-	S.LH8B26S.A..L..SA	3+7	1550	1740	/	1180	/	948	1375	415	500	25,8	3	
A-	N-	S.LH8B37S.A..M..SA	3+7	1550	2235	/	1675	/	948	1375	415	582	37,1	4	
A-	N-	S.LH8B49S.A..P..SG	3+7	1550	2790	/	2095	/	1007	1531	335	697	48,6	5,5	
A-	N-	S.LH8B54S.A..R..SG	3+7	1550	3030	/	2335	/	1007	1531	335	736	54,2	7,5	
A-	N-	S.LH8B63S.A..R..SG	3+7	1550	3400	/	2705	/	1007	1531	335	791	62,7	7,5	



# VACUUM BAG-FILTERS - EX-PROOF VACUUM BAG-FILTERS

DN 350 - 1100

## A-N-SEL.....V A-N-SFL.....V - A-SEL.....Q A-SFL.....Q

### UPPER BODY

Fig.01

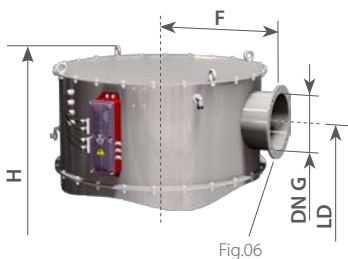
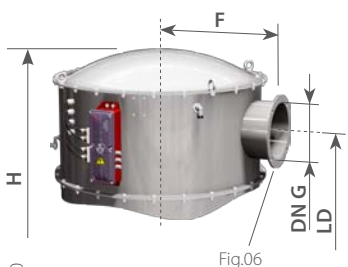

Fig.02



NOTE: Fig.05-06-07 a pag.10

### LOWER BODY

Fig.03

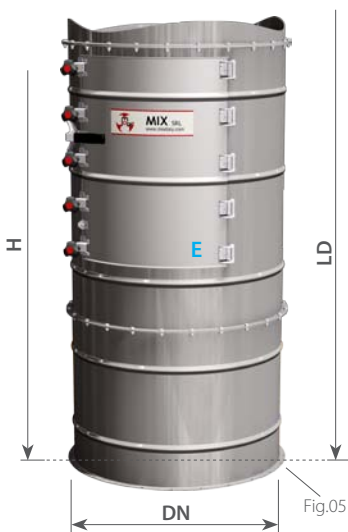

F - Without inspection door

E - With inspection door

\* Nominal surface

CODE			Fig.	DN	H	LD	DN G	F	kg	m2*
ATEX	STD.	See combination table								
A-	N-	SFLD2A10V.A..ZZ.SA	1+6	350	1130	960	80	235	27	1
A-	/	SFLD2A10Q.A..ZZ.SA								
A-	N-	SFLD2A17V.A..ZZ.SA	1+6	350	1630	1460	80	235	34	1,7
A-	/	SFLD2A17Q.A..ZZ.SA								
A-	N-	S.LD3A21V.A..ZZ.SA	2+6	540	1165	980	150	370	72	2,1
A-	/	S.LD3A21Q.A..ZZ.SA								
A-	N-	S.LD3A39V.A..ZZ.SA	2+6	540	1665	1480	150	370	96	3,9
A-	/	S.LD3A39Q.A..ZZ.SA								
A-	N-	S.LD3A56V.A..ZZ.SA	2+6	540	2160	1975	150	370	115	5,6
A-	/	S.LD3A56Q.A..ZZ.SA								
A-	N-	S.LD3A73V.A..ZZ.SC	2+6	540	2660	2475	150	370	134	7,3
A-	/	S.LD3A73Q.A..ZZ.SC								
A-	N-	SELD4A48V.A..ZZ.SA	2+6	790	1225	940	200	495	128	4,8
A-	/	SELD4A48Q.A..ZZ.SA								
A-	N-	SELD4A86V.A..ZZ.SA	2+6	790	1725	1440	200	495	168	8,6
A-	/	SELD4A86Q.A..ZZ.SA								
A-	N-	SELD4B12V.A..ZZ.SA	2+6	790	2220	1935	200	495	206	12,4
A-	/	SELD4B12Q.A..ZZ.SA								
A-	N-	SELD4B16V.A..ZZ.SC	2+6	790	2760	2435	200	495	241	16,2
A-	/	SELD4B16Q.A..ZZ.SC								
A-	N-	SELD5A67V.A..ZZ.SA	2+6	950	1305	935	250	580	195	6,7
A-	/	SELD5A67Q.A..ZZ.SA								
A-	N-	SELD5B12V.A..ZZ.SA	2+6	950	1805	1435	250	580	244	12
A-	/	SELD5B12Q.A..ZZ.SA								
A-	N-	SELD5B17V.A..ZZ.SC	2+6	950	2300	1930	250	580	293	17,3
A-	/	SELD5B17Q.A..ZZ.SC								
A-	N-	SELD5B23V.A..ZZ.SC	2+6	950	2800	2430	250	580	338	22,7
A-	/	SELD5B23Q.A..ZZ.SC								
A-	N-	SELD5B25V.A..ZZ.SG	2+6	950	3040	2670	250	580	359	25,3
A-	/	SELD5B25Q.A..ZZ.SG								
A-	N-	SELD6A93V.A..ZZ.SA	2+6	1100	1255	935	250	660	235	9,3
A-	/	SELD6A93Q.A..ZZ.SA								
A-	N-	SELD6B17V.A..ZZ.SA	2+6	1100	1755	1435	250	660	295	16,7
A-	/	SELD6B17Q.A..ZZ.SA								
A-	N-	SELD6B24V.A..ZZ.SA	2+6	1100	2250	1930	250	660	354	24,1
A-	/	SELD6B24Q.A..ZZ.SA								
A-	N-	SELD6B32V.A..ZZ.SC	2+6	1100	2750	2430	250	660	410	31,6
A-	/	SELD6B32Q.A..ZZ.SC								
A-	N-	SELD6B35V.A..ZZ.SG	2+6	1100	2990	2670	250	660	436	35,2
A-	/	SELD6B35Q.A..ZZ.SG								

## A-N-SFL.....V A-N-SJL.....V - A-SFL.....Q A-SJL.....Q

### UPPER BODY

Fig.02

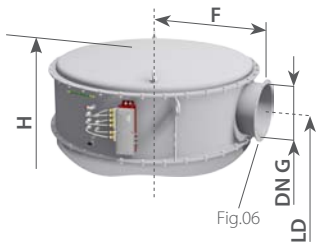

NOTE: Fig.05-06-07 a pag.10

### LOWER BODY

Fig.03

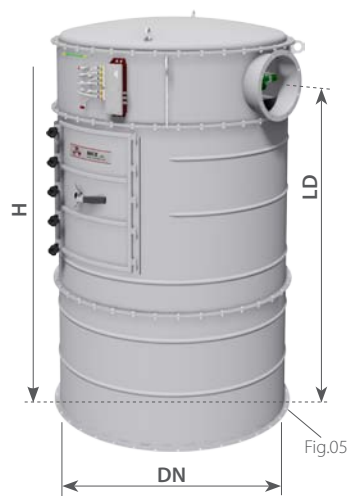

**F** - Without inspection door  
**J** - Double inspection door  
 \* Nominal surface

CODE			Fig.	DN	H	LD	DN G	F	kg	m2*
ATEX	STD.	See combination table								
A-	N-	S.LD7B20V.A..ZZ.SA	2+6	1300	1740	1430	323	750	393	19,7
A-	/	S.LD7B20Q.A..ZZ.SA								
A-	N-	S.LD7B29V.A..ZZ.SA	2+6	1300	2235	1925	323	750	462	28,5
A-	/	S.LD7B29Q.A..ZZ.SA								
A-	N-	S.LD7B37V.A..ZZ.SG	2+6	1300	2735	2425	323	750	527	37,3
A-	/	S.LD7B37Q.A..ZZ.SG								
A-	N-	S.LD7B42V.A..ZZ.SG	2+6	1300	2975	2665	323	750	558	41,5
A-	/	S.LD7B42Q.A..ZZ.SG								
A-	N-	S.LD7B48V.A..ZZ.SG	2+6	1300	3345	3035	323	750	607	48
A-	/	S.LD7B48Q.A..ZZ.SG								
A-	N-	S.LD8B26V.A..ZZ.SA	2+6	1550	1785	1430	323	875	533	25,8
A-	/	S.LD8B26Q.A..ZZ.SA								
A-	N-	S.LD8B37V.A..ZZ.SA	2+6	1550	2280	1925	323	875	618	37,1
A-	/	S.LD8B37Q.A..ZZ.SA								
A-	N-	S.LD8B49V.A..ZZ.SG	2+6	1550	2780	2425	323	875	698	48,6
A-	/	S.LD8B49Q.A..ZZ.SG								
A-	N-	S.LD8B54V.A..ZZ.SG	2+6	1550	3020	2665	323	875	735	54,2
A-	/	S.LD8B54Q.A..ZZ.SG								
A-	N-	S.LD8B63V.A..ZZ.SG	2+6	1550	3390	3035	323	875	797	62,7
A-	/	S.LD8B63Q.A..ZZ.SG								



## A-SEL....P

## A-SFL....P

### UPPER BODY

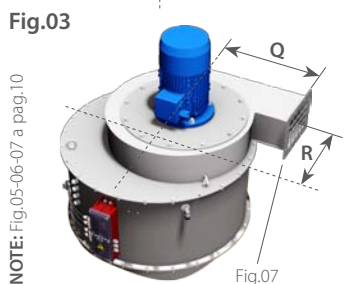
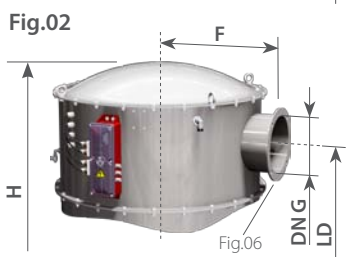
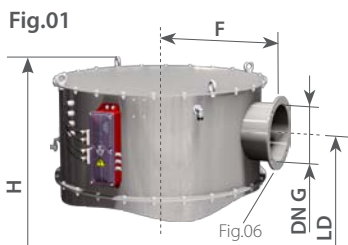

### LOWER BODY



F - Without inspection door  
E - With inspection door  
\* Nominal surface

CODE		Fig.	DN	H	LD	DN G	R	F	Q	kg	m2*	kW
ATEX	See combination table											
A-	SFLD2A10P.A..ZZ.SA	1+6	350	1130	960	80	/	235	/	27	1	/
A-	SFLD2A17P.A..ZZ.SA	1+6	350	1630	1460	80	/	235	/	34	1,7	/
A-	S.LD3A21P.A..ZZ.SA	2+6	540	1165	980	150	/	370	/	72	2,1	/
A-	S.LD3A39P.A..ZZ.SA	2+6	540	1665	1480	150	/	370	/	96	3,9	/
A-	S.LD3A56P.A..ZZ.SA	2+6	540	2160	1975	150	/	370	/	115	5,6	/
A-	S.LD3A73P.A..ZZ.SC	2+6	540	2660	2475	150	/	370	/	134	7,3	/
A-	SELD4A48P.A..ZZ.SA	2+6	790	1225	940	200	/	495	/	128	4,8	/
A-	SELD4A86P.A..ZZ.SA	2+6	790	1725	1440	200	/	495	/	168	8,6	/
A-	SELD4B12P.A..ZZ.SA	2+6	790	2220	1935	200	/	495	/	206	12,4	/
A-	SELD4B16P.A..ZZ.SC	2+6	790	2760	2435	200	/	495	/	241	16,2	/
A-	SELD5A67P.A..ZZ.SA	2+6	950	1305	935	250	/	580	/	195	6,7	/
A-	SELD5B12P.A..ZZ.SA	2+6	950	1805	1435	250	/	580	/	244	12	/
A-	SELD5B17P.A..ZZ.SC	2+6	950	2300	1930	250	/	580	/	293	17,3	/
A-	SELD5B23P.A..ZZ.SC	2+6	950	2800	2430	250	/	580	/	338	22,7	/
A-	SELD5B25P.A..ZZ.SG	2+6	950	3040	2670	250	/	580	/	359	25,3	/
A-	SELD6A93P.A..ZZ.SA	2+6	1100	1255	935	250	/	660	/	235	9,3	/
A-	SELD6B17P.A..ZZ.SA	2+6	1100	1755	1435	250	/	660	/	295	16,7	/
A-	SELD6B24P.A..ZZ.SA	2+6	1100	2250	1930	250	/	660	/	354	24,1	/
A-	SELD6B32P.A..ZZ.SC	2+6	1100	2750	2430	250	/	660	/	410	31,6	/
A-	SELD6B35P.A..ZZ.SG	2+6	1100	2990	2670	250	/	660	/	436	35,2	/
A-	SFLH2A10P.A..A..SA	3+7	350	1460	1150	/	200	/	256	56	1	0,75
A-	SFLH2A17P.A..A..SA	3+7	350	1960	1640	/	200	/	256	63	1,7	0,75
A-	S.LH3A21P.A..A..SA	3+7	540	1485	1175	/	226	/	288	95	2,1	0,75
A-	S.LH3A39P.A..C..SA	3+7	540	1985	1675	/	226	/	288	121	3,9	1,1
A-	S.LH3A56P.A..E..SC	3+7	540	2510	2175	/	235	/	374	147	5,6	1,5
A-	S.LH3A73P.A..E..SC	3+7	540	3010	2675	/	235	/	374	166	7,3	1,5
A-	SELH4A48P.A..E..SA	3+7	790	1510	1180	/	300	/	400	158	4,8	1,5
A-	SELH4A86P.A..E..SA	3+7	790	2010	1680	/	300	/	400	198	8,6	1,5
A-	SELH4B12P.A..G..SC	3+7	790	2535	2175	/	300	/	400	241	12,4	2,2
A-	SELH4B16P.A..G..SC	3+7	790	3035	2675	/	300	/	400	276	16,2	2,2
A-	SELH5A67P.A..E..SA	3+7	950	1530	1200	/	345	/	484	219	6,7	1,5
A-	SELH5B12P.A..G..SA	3+7	950	2060	1700	/	345	/	484	273	12	2,2
A-	SELH5B17P.A..G..SC	3+7	950	2555	2195	/	345	/	484	322	17,3	2,2
A-	SELH5B23P.A..L..SC	3+7	950	3085	2700	/	290	/	515	385	22,7	3
A-	SELH5B25P.A..L..SG	3+7	950	3325	2940	/	290	/	515	405	25,3	3
A-	SELH6A93P.A..E..SA	3+7	1100	1530	1200	/	526	/	430	264	9,3	1,5
A-	SELH6B17P.A..G..SA	3+7	1100	2060	1700	/	526	/	430	328	16,7	2,2
A-	SELH6B24P.A..L..SC	3+7	1100	2585	2200	/	580	/	310	405	24,1	3
A-	SELH6B32P.A..L..SC	3+7	1100	3085	2700	/	580	/	310	462	31,6	3
A-	SELH6B35P.A..M..SG	3+7	1100	3390	2940	/	580	/	310	496	35,2	4



## A-SFL....P

## A-SJL....P

### UPPER BODY

Fig.01

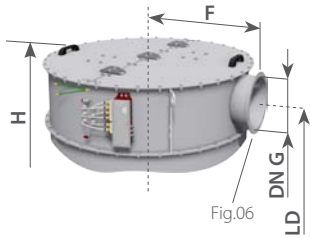
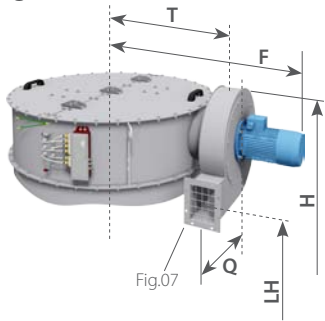

Fig.03



NOTE: Fig.05-06-07 a pag.10

### LOWER BODY

Fig.04



F - Without inspection door  
 J - Double inspection door  
 \* Nominal surface

CODE		Fig.	DN	H	LD	LH	DN G	T	F	Q	kg	m2*	kW
ATEX	See combination table												
A-	S.LD7B20P.A..ZZ.SA	1+6	1300	1670	1430	/	323	/	750	/	375	19,7	/
A-	S.LD7B29P.A..ZZ.SA	1+6	1300	2165	1925	/	323	/	750	/	443	28,5	/
A-	S.LD7B37P.A..ZZ.SG	1+6	1300	2665	2425	/	323	/	750	/	506	37,3	/
A-	S.LD7B42P.A..ZZ.SG	1+6	1300	2905	2665	/	323	/	750	/	540	41,5	/
A-	S.LD7B48P.A..ZZ.SG	1+6	1300	3275	3035	/	323	/	750	/	588	48	/
A-	S.LD8B26P.A..ZZ.SA	1+6	1550	1670	1430	/	323	/	875	/	495	25,8	/
A-	S.LD8B37P.A..ZZ.SA	1+6	1550	2165	1925	/	323	/	875	/	579	37,1	/
A-	S.LD8B49P.A..ZZ.SG	1+6	1550	2665	2425	/	323	/	875	/	659	48,6	/
A-	S.LD8B54P.A..ZZ.SG	1+6	1550	2905	2665	/	323	/	875	/	697	54,2	/
A-	S.LD8B63P.A..ZZ.SG	1+6	1550	3275	3035	/	323	/	875	/	758	62,7	/
A-	S.LH7B20P.A..L..SA	3+7	1300	1740	/	1180	/	823	1250	415	436	19,7	3
A-	S.LH7B29P.A..L..SA	3+7	1300	2235	/	1675	/	823	1250	415	505	28,5	3
A-	S.LH7B37P.A..M..SG	3+7	1300	2735	/	2175	/	823	1250	415	579	37,3	4
A-	S.LH7B42P.A..M..SG	3+7	1300	2975	/	2415	/	823	1250	415	610	41,5	4
A-	S.LH7B48P.A..P..SG	3+7	1300	3400	/	2705	/	882	1406	335	705	48	5,5
A-	S.LH8B26P.A..L..SA	3+7	1550	1740	/	1180	/	948	1375	415	557	25,8	3
A-	S.LH8B37P.A..M..SA	3+7	1550	2235	/	1675	/	948	1375	415	649	37,1	4
A-	S.LH8B49P.A..P..SG	3+7	1550	2790	/	2095	/	1007	1531	335	776	48,6	5,5
A-	S.LH8B54P.A..R..SG	3+7	1550	3030	/	2335	/	1007	1531	335	820	54,2	7,5
A-	S.LH8B63P.A..R..SG	3+7	1550	3400	/	2705	/	1007	1531	335	882	62,7	7,5



## FASTENING FLANGES AT THE BASE

Fig.05

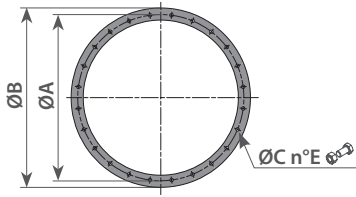

DN	ØA	ØB	ØC	n°E	
350	382	402	9	12	M8
540	570	590	9	16	M8
790	820	840	9	24	M8
950	996	1024	11	28	M10
1100	1154	1182	11	32	M10
1300	1338	1365	11	36	M10
1550	1588	1615	11	44	M10

## OUTLET FLANGES

Fig.06

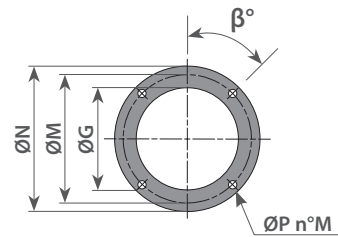

DN	ØG	ØM	ØN	ØP	n°M	β°
350	80	130	160	14	4	45
540	168	200	228	14	4	45
790	219	250	278	14	4	45
950	273	300	328	14	8	22,5
1100	273	300	328	14	8	22,5
1300	323	350	378	14	8	22,5
1550						

## FANS FLANGES

Fig.07

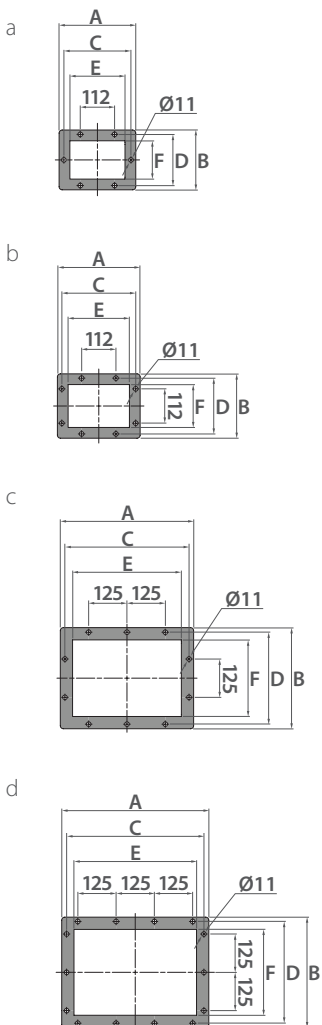

TYPE	Fig.	kW	A (mm)	B (mm)	C (mm)	D (mm)	E (mm)	F (mm)
MBS330	07a	0,75	230	182	200	153	156	112
MBS360	07a	1,1	230	182	200	153	156	112
MBS385	07a	1,5	250	195	219	167	180	125
MBS415	07a	2,2	250	195	219	167	180	125
MBS430	07b	3	270	210	241	182	200	140
MBS460	07b	4	270	210	241	182	200	140
MBV420	07c	5,5	435	330	405	300	355	250
MBV450	07c	7,5	435	330	405	300	355	250
MBV500	07d	11	480	360	448	332	400	280

## PACKAGING

**A** Packaging above a pallet (upright); Protected by a carton box, or bubble wrap

**C** Packaging above 2 pallets (upright), head and Venturis not installed; Protected by a carton box, or bubble wrap

**G** Horizontal packaging above a wooden bed; Protected by bubble wrap

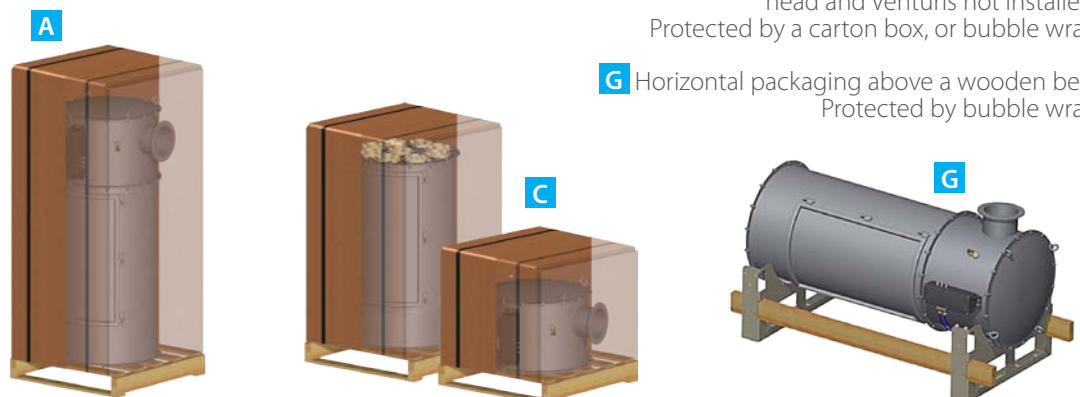

**NOTE:**All dimensions in mm, unless stated otherwise. The Company MIX reserves the right to alter product specifications without prior notice. All the quoted sizes are approximate. The given figures are mean values with tolerances entailed by the customary production-related variations. In any particular case, and to have the correct values, our written confirmation is necessary.

## Bag

### BAG



### BAG FABRICS - Polyester needle felt

Type	g/m <sup>2</sup>	Antistatic	Diaphragm	Notes	Filter Cage	Flange
13	450	/	/	/	Electrogalvanized Carbon Steel	Polymer
14	450	✓	/	Stainless steel fibres		
16	550	/	/	/		
17	470	/	✓	Polyurethane diaphragm 15		
18	550	✓	/	Teflon-coated Stainless steel fibres		
19	550	/	✓	PTFE diaphragm 3		
20	450	/	/	Teflon-coated		
21	550	/	/	Teflon-coated		
22	550	✓	/	Stainless steel fibres		
23	500	✓	✓	Stainless steel fibres - PTFE diaphragm 3		
24	500	/	✓	PTFE diaphragm 5		
25	500	✓	✓	Stainless steel fibres - PTFE diaphragm 5		

Stainless steel Filter Cage on request

MIX filtering elements have coupling types which allow for their mounting on both MIX dust collectors: with side access, and with extraction from the top.

*REMARK: Dust collectors should be in the models prepared for pin fastening system.*

## NOTE

# FILTERING SYSTEMS AND COMPONENTS FOR PLANTS

QUALITY  
SERVICE  
TECHNOLOGY  
INNOVATION

[www.mixitaly.com](http://www.mixitaly.com)



**MIX S.r.l.** - 41032 CAVEZZO (MO) - Via Volturmo, 119/A - ITALY  
Tel. +39 0535.46577 - Fax +39 0535.46580 - [info@mixitaly.com](mailto:info@mixitaly.com)